

BBS charging

standard

longitudinal edges standard profiles on both sides
transverse edges cut rightangled | tolerance + 10 mm

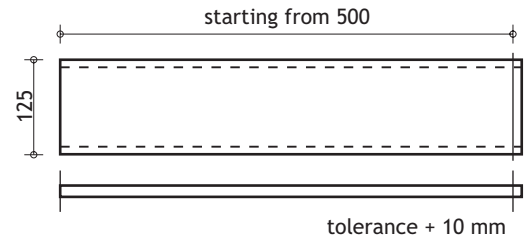

CNC-machining

longitudinal edges standard profiles on both sides
transverse edges cut rightangled or angled

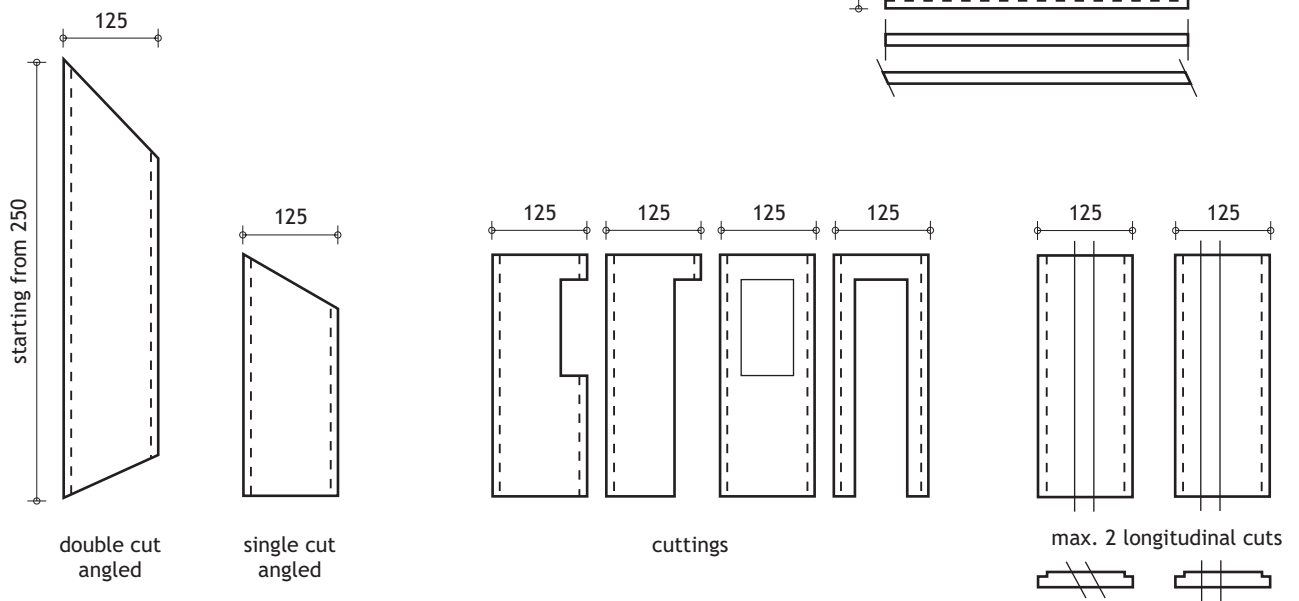

general

charging	charging width = 125 cm 62,5 cm lengths are rounded up to full cm the circumlocutory rectangle sets the standard
not included	machining at transverse edges [notches, millcutting, flatterring] cuttings < 25 cm round resp. curved machining drilling, slots, ...
tools	5-axial chain saw max. cutting depth = 40 cm milling cutter diameter 80 mm, 100 mm
special machining	on request surcharge